

Design of a Small-Scale Biodiesel Production System

Jeffrey Anderson, Jessica Caceres, Ali Khazaei, Jediah Shirey

Abstract – The city of Fredericksburg is located in central Virginia and is home to 592 farms covering 16% of the total land area. Farms in this region have experienced declining profits from an average of \$555 per farm in 1997 to -\$14,931 per farm in 2007. One of the ways to reduce operating costs and return to profitability is to significantly reduce diesel costs. An alternative to purchasing diesel is to produce biodiesel from vegetable oil extracted from crops grown on the farm and sell the excess biodiesel that is not used. The goal of this paper is to design the process and evaluate the financial feasibility of converting farm crops into biodiesel using a small-scale biodiesel production facility on a farm.

Five crops were selected as design alternatives based on regional availability, productivity, and cost criteria: Canola, Corn, Peanut, Soybean, and Sunflower. These alternatives were evaluated using two Monte Carlo models: (1) a Biodiesel Production Model to simulate the amount of biodiesel and other byproducts produced and (2) a Business Model to simulate the net present value of each alternative after 15 years. The biodiesel production model inputs are: (i) expected crop yield, (ii) oil content percentage, and (iii) oil press efficiency percentage. The outputs of this model are: (i) biodiesel yield, (ii) meal yield, (iii) glycerin yield, and (iv) net energy ratio; each of the yield outputs is an input for the financial model. Other inputs for the financial model include meal revenue, equipment costs, chemical expenses, planting and harvesting costs, lost profit cost, and biodiesel sales. The output is the net present value of each crop alternative at the end of 15 years.

Utility of each crop alternative from first to last is as follows: Peanut (1.0), Sunflower (0.68), Canola (0.55), Soybean (0.52), and Corn (0.45). Plotting utility against net present value shows that Canola is the most cost-effective alternative and the recommended crop type.

I. INTRODUCTION

Fredericksburg, Virginia is an independent city approximately 50 miles south of Washington, D.C. and encompassed by the counties of Spotsylvania and Stafford. These two counties are home to 592 farms ranging from 1 to 2,000+ acres, with an average size of 115 acres. These farms have a total of 72,000 acres of farmland, of which over 34,000 acres are cropland [1].

The United States Department of Agriculture (USDA) defines a farm as “any place from which \$1,000 or more of agricultural products were produced and sold, or normally

would have been sold, during the census year” [1]. The value of sales is the amount of income generated by the selling of agricultural commodities. Essentially, it is the farm’s paycheck before expenses. In 2007, 41.6% of farms in the Fredericksburg area had value of sales below \$1,000, and 0.34% had value of sales greater than or equal to \$500,000. The USDA further defines farms by size: small farms are farms with \$250,000 or less in sales of agricultural commodities [2]. In 2007 over 98% of the farms in Fredericksburg were, by USDA definition, small farms. This paper is specifically interested in these farms.

The income of operation or income from operations (IFO) is the total profit realized by a business after all costs are deducted from all business related income to include total sales, government payments, and other farm related income [1].

For the years 2002 and 2007, USDA data shows that the total income from operations (IFO) of Fredericksburg farms is negative. The average income from operations for farms in Fredericksburg has decreased from approximately \$500 per year in 1997 to approximately -\$15,000 per year in 2007 [1], [3], [4].

The total farm IFO deficit has increased over 77% from \$2.45 million in 2002 to \$4.33 million in 2007. Data also show that the year 1997 was the last time farmers had a positive IFO [1], [3], [4]. Farmers are collectively and on average losing money. Any business sustaining losses such as these will not be sustainable in the long run.

A factor affecting profit is the increase of farm production expenses from approximately \$23,800 per farm in 1997 to \$30,500 per farm in 2007. Oil price dependent categories such as fertilizers, lime, and soil conditioners and gasoline, fuels, and oils have increased by 122% and 137% respectively from 1997 to 2007 [1], [4]. Collectively, these categories make up 21% of the total production expenses. The price of diesel in the Central Atlantic Region of the United States has increased by nearly 230% since 1997 [5], causing production expenses to rise as the cost of oil price dependent categories increases.

An alternative to purchasing diesel is to produce biodiesel from vegetable oil extracted from crops grown on the farm.

II. BIODIESEL PRODUCTION

Biodiesel is a biofuel made from living or recently living organisms such as algae, animal fats, or vegetable oils and can be used in diesel engines without the need for engine modification. Biodiesel is biodegradable and a cleaning and lubricating agent which helps increase the life of diesel engines.

Manuscript received April 1, 2013. This work was supported in part by Dr. Terence Thompson of North Point Farm. All authors are students at the Volgenau School of Engineering, Department of Systems Engineering and Operations Research, George Mason University, Fairfax, Virginia 22030 United States of American.

J. Anderson (email: jander12@gmu.edu), J. Caceres (email: jcaceres@gmu.edu), A. Khazaei (email: akhazaei@gmu.edu), and J. Shirey (email: jshirey@gmu.edu).

A. Biodiesel Production Process

Fig. 1 depicts the biodiesel production process on a farm.

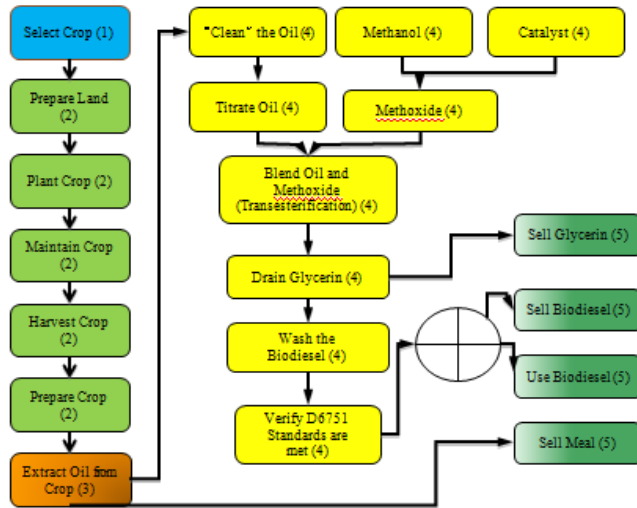

Fig. 1. The biodiesel production process involves 5 major steps: (1) Select a crop to use for vegetable oil, (2) Plant crop and harvest when fully grown, (3) Extract oil from harvested crop, (4) Perform transesterification to convert vegetable oil to biodiesel, and (5) Use or sell biodiesel and other byproducts of process. Step (3) is performed by a vegetable oil press and Step (4) is performed by a biodiesel processor.

B. Hazards

As part of the transesterification process, methanol and a catalyst, potassium hydroxide, are used. Each of these chemicals has the potential to be hazardous if not used correctly. Methanol is flammable and can be ignited under almost all ambient temperatures. Potassium hydroxide is an irritant and cause serious damage if exposed to human skin. Although potentially hazardous, these chemicals pose no significant risk to human operators if handled with care.

C. Net Energy Ratio

The net energy ratio is the units of energy obtained from biodiesel divided by the units of energy that go into biodiesel production. If the net energy ratio of an energy source is less than 1, then the amount of energy required to produce that source is greater than the amount of energy gained from using it and is therefore not beneficial. Thus, a requirement of the biodiesel production system is that biodiesel be produced with a net energy ratio greater than 1.

III. STAKEHOLDER ANALYSIS

A. Farmers

Farmers located in the Fredericksburg area are the primary stakeholders for this project. The farmer's main objective is to make money by reducing operating costs and producing a quality product to sell. Producing their own fuel has the potential to reduce operating costs and cause the farmer to gain a positive net profit. The farmer also must minimize the amount of land dedicated to producing biodiesel in order to continue to profitably produce and sell crops.

B. Neighboring Farmers

The main objective of the neighboring farmers in regards to biodiesel is to minimize safety hazards. They do not want to be affected by hazardous spills that can cause land or water contamination, or be affected by odors that may be caused by biodiesel production.

C. Workers

Farmers that decide to produce their own biodiesel offer the opportunity for new jobs in Fredericksburg. The workers' objective is to earn a salary by helping with the production process of biodiesel for the primary stakeholder. Safety is also an important matter; working in a safe environment minimizes the risks involved in the production procedures, helps them perform their duties correctly and avoids possible extra expenses due to accidents. The farmer will have to provide them with proper safety gear such as boots, gloves, face shield, and goggles to be able to handle hazardous materials in a safe manner.

D. Food Consumers

One of the disadvantages of increased biodiesel production in the United States is possible food shortage in the future. Farmers choosing to plant more acres of crops dedicated to biodiesel production will also be less likely to meet market demand for food in the long-run. This decision can cause the food crop supply to decrease and result in increasing crop prices. Thus, it is essential that farmers select a crop type that maximizes biodiesel yield so that the impact on food supply is minimized.

E. Government

The government's objective is to promote non-polluting alternative fuels while also achieving energy independence. They are interested in increasing the United States' national energy security, improving air quality and public health, and developing economic, academic, and research opportunities in the Commonwealth of Virginia. Government agencies, such as the Internal Revenue Service (IRS) and the Virginia Department of Taxation, support increasing biodiesel production by creating tax incentives and giving grants to biodiesel producers.

F. Stakeholder Tensions

Neighboring farmers want to make sure that the biodiesel production is done in a safe manner and will not cause hazardous spills, water and land contamination, or the presence of unpleasant odors on their property. Employees need to be provided with the appropriate working gear to avoid hazardous accidents. Preventing these accidents from occurring will increase biodiesel production expenses and create tensions between farmers and their neighbors and employees. As biodiesel production increases, decreasing food supplies will create tensions between farmers and consumers. Lastly, the government provides incentives for the production of alternative sources of fuel, but they also have regulatory agencies that control and regulate biodiesel

production and make sure it is done in a safe manner. Farmers who want to sell biodiesel have to abide by the American Society for Testing and Materials (ASTM) Standard D6751 [6] which specifies the requirements for biodiesel that is sold. Producing biodiesel according to this standard can increase production costs as it requires precise measurements and quality storage containers.

The biodiesel system designed in this project will merge the needs and objectives of all the stakeholders and will create a win-win solution financially for all stakeholders.

IV. STATEMENT OF NEED

A. Problem Statement

Increasing fuel prices and lack of net profit threaten the long term sustainability of farms located in Fredericksburg. Farmers rely heavily on petrochemical diesel, which has increased in price by nearly 230% since 1997[5] - the last year that farmers in the Fredericksburg area of Virginia had an average net profit.

B. Statement of Need

There is a need for a small-scale biodiesel production system for farms located in Fredericksburg. The design of the biodiesel production system will take into account the whole life-cycle process of biodiesel production, from crop planting to the final biodiesel yield. A win-win situation for all stakeholders will be achieved by helping farmers save money on fuel costs through biodiesel production while creating new product to sell, providing farmers with the proper information to minimize hazardous spills and safety risks, minimizing the impact on food supplies by recommending the optimal crop type, and furthering the government's goal of energy independence.

V. DESIGN ALTERNATIVES

To produce biodiesel, four components are necessary: (1) a crop source, (2) a vegetable oil press, (3) a biodiesel processor, and (4) a biodiesel storage tank. Detailed analysis of the off-the-shelf equipment (vegetable oil press, biodiesel processor, and biodiesel storage tank) showed that they were similar in performance and cost and did not provide any advantages from one to another. This left the most critical aspect of the design, the vegetable oil source. This decision exhibits the most amount of variability (e.g. crop yield), affects the productivity of the process (i.e. biodiesel yield per acre), and has the most significant yearly impact on costs. Five crop alternatives were identified based on regional availability, productivity, and cost criteria: Canola, Corn, Peanut, Soybean, and Sunflower. These crops vary in the amount of vegetable oil they contain, as well as in the amount of valuable byproduct (meal and glycerin) that they produce.

Of these crop alternatives, Peanut, Soybean, and Corn are currently grown in Virginia as crops whereas Canola and

Sunflower are not widely grown (although the climate is favorable for their growth).

VI. METHOD OF ANALYSIS

The method of analysis includes three processes: the Biodiesel Production Model, the Business Model, and the utility function. The Biodiesel Production Model simulates the expected value for the biodiesel yield for each alternative and the Business Model simulates the expected net present value (NPV) associated with each alternative at the end of the system lifespan. The utility function is based on a value hierarchy containing three discriminators: biodiesel yield (gallons per acre) and length of planting, harvesting season (days), and the hazard level. Biodiesel yield values are supplied by the Biodiesel Production Model. The utility of each alternative will be plotted versus the NPV of each alternative in the utility analysis.

Each model is a Monte Carlo simulation, and the relationship between the two models is depicted in Fig. 2.

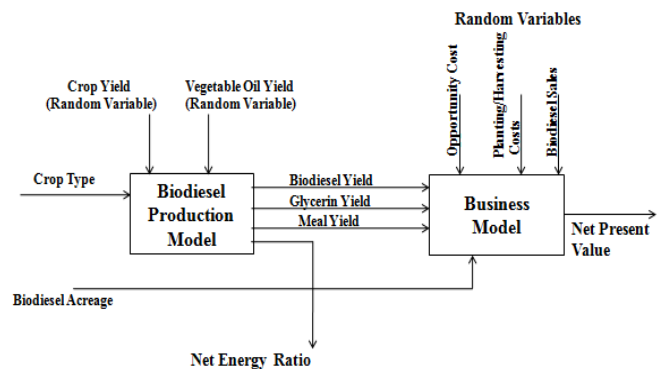

Fig. 2. Monte Carlo simulation containing two models: Biodiesel Production Model and Business Model. Biodiesel Production Model simulates the expected yield of biodiesel and other byproducts which are then inputs to the Business Model. The Business Model accounts for all of the variable costs associated with biodiesel production and calculates the NPV at the end of 15 years.

A. Model Assumptions

The following assumptions were made for the model:

- 1) The lifespan of the machinery is 15 years
- 2) The farm contains 75 acres of cropland
- 3) There is no salvage value for the machinery at the end of the system lifespan
- 4) Farmers own the proper equipment to plant and harvest crops
- 5) There exists unlimited demand for biodiesel, glycerin, and meal
- 6) After the first year of biodiesel production, all fuel needs will be supplied by the previous year's biodiesel

B. Biodiesel Production Model

In order to model the uncertain nature of biodiesel production, crop yield and vegetable oil press efficiency were used as random variable inputs. Distributions for the

crop yield are based on historical crop yields for the Fredericksburg area (Corn [1], the state of Virginia (Canola [11] and Peanut [12]), and the United States (Sunflower [13] and Soybean [14]). The outputs of the biodiesel model are expected biodiesel yield, expected glycerin yield, expected meal yield, and the net energy ratio. These values were calculated using (1), (2), and (3) below [7], [8]. Table I lists the variables used to calculate the yields.

TABLE I
BIO DIESEL PRODUCTION MODEL VARIABLES

Symbol	Description
B_{ypa}	Biodiesel Yield per Acre (gallons)
C_{ypa}	Crop Yield per Acre (lbs)
O_c	Oil Content by Weight (percentage)
$W_{biodiesel}$	Pounds per Gallon of Biodiesel (~7.6 lbs/gal)
P_{eff}	Oil Press Efficiency (percentage)
M_{ypa}	Meal Yield per Acre (lbs)
G_{ypa}	Glycerin Yield per Acre (gallons)
G_{yr}	Glycerin Yield Ratio (0.105)
B_{yr}	Biodiesel Yield Ratio (0.9885)

$$B_{ypa} = \frac{C_{ypa} * O_c}{W_{biodiesel} * 100} * P_{eff} / 100 * B_{yr} \quad (1)$$

$$M_{ypa} = C_{ypa} * (1 - (O_c * P_{eff}) / 10000) \quad (2)$$

$$G_{ypa} = \frac{C_{ypa} * O_c}{W_{biodiesel} * 100} * P_{eff} / 100 * G_{yr} \quad (3)$$

The factor with the largest impact on the yield amount is the crop yield and the oil content of the crop - both of which are random variables based on historical data from the USDA. The alternatives range from 4% oil content for corn to 43% oil content for sunflower. Meal yield is inversely proportional to the vegetable oil content of the crop; high oil content tends to produce lower meal yield. Meal and glycerin yield were calculated because these byproducts can be sold to offset the cost of biodiesel production. The yield equations were used to calculate the expected yields for each year that the simulation was run.

C. Business Model

The random variable inputs for the model include the outputs from the Biodiesel Production Model (biodiesel, glycerin, and meal yield) as well as planting and harvesting costs, opportunity cost, meal revenue, and glycerin revenue. Opportunity cost represents the profit lost by not selling the crop as a food source. Other inputs are machinery costs, chemical costs, state biodiesel incentives, and the number of acres committed to biodiesel production. The output is the NPV for each crop alternative. Equation (4) was used to calculate the NPV for the lifespan of the system.

$$I_0 + \sum_{t=1}^n F_t / (1 + k + p)^t \quad (4)$$

I_0 is the initial machinery investment, F_t is the net cash flow in year t, k is the discount factor, p is the inflation rate per year, and n is the number of years. Values for p were obtained from the U.S. Bureau of Labor Statistics inflation forecast [9] and the duration of the model was determined to be 15 years based on the lifespan of the machinery. Equation (5) was used to calculate the net cash flow for each year [10], and Table II describes the variables for (5).

$$F_t = (-F_c - PH_c - O_c + G_r + M_r + S_t) * B_A + B_P - M_c \quad (5)$$

TABLE II
BUSINESS MODEL VARIABLES

Symbol	Description
F_c	Chemical expenses (dollars per acre)
PH_c	Crop costs (dollars per acre)
O_c	Opportunity cost (dollars per acre)
G_r	Glycerin revenue (dollars per acre)
M_r	Meal revenue (dollars per acre)
B_P	Biodiesel sales (dollars)
B_A	Biodiesel acreage on farm (acres)
M_c	Yearly maintenance costs (dollars)
S_t	State biodiesel incentives (dollars per acre)

The output of this model is the net present value of biodiesel production for each crop after 15 years.

VII. RESULTS

A. Biodiesel Production Model

50,000 iterations of each simulation were run with the assumption that the farm had 75 acres of cropland. Nine simulation scenarios were run for biodiesel acreage of 10, 15, and 20 acres and discount rates of 2%, 5%, and 7%. Table III shows the results of the Biodiesel Production Model ranked from highest yield per acre to the lowest. These factors are not affected by the biodiesel acreage or the discount rate and remain constant for each simulation scenario.

TABLE III
PRODUCTION MODEL OUTPUTS

Crop	Bioiesel Yield	NER
Peanut	136 gal/acre	4.09
Sunflower	62 gal/acre	3.05
Canola	102 gal/acre	3.43
Soybean	35 gal/acre	1.77
Corn	19 gal/acre	0.84

Corn has the lowest biodiesel yield at 19 gallons per acre. Canola and Peanut have significantly higher biodiesel yields – about 5 and 7 times the Corn yield respectively.

As a result, Corn has a NER that is significantly lower than the other crops because the amount of biodiesel from corn is lower. The NER for Corn is lower than 1 and does not meet the requirement that biodiesel be produced with a NER greater than 1. Peanut and Canola have relatively high NER consistent with the higher biodiesel yield.

B. Business Model Results

Fig. 3 shows the mean net present value results for each crop alternative for a discount rate of 2%.

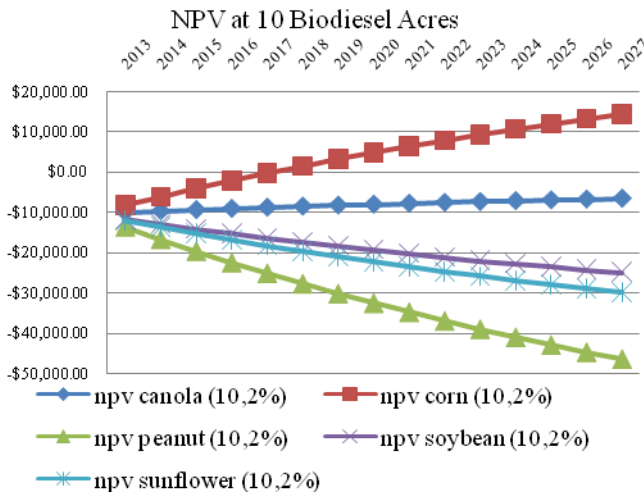

Fig. 3. Based on the average NPV results, Corn produces a positive return on investment (ROI) within 5 years and is the only alternative that produces a ROI. Corn has the lowest biodiesel yield but the highest meal yield which provides a significant contribution to profit.

With 10 acres committed to biodiesel production, Corn is the only alternative with a positive average NPV. Based on the NPV distribution, Corn has an 80% chance of achieving a positive NPV. Canola has a 14% chance of achieving a positive NPV. Peanut, Soybean, and Sunflower all have a 0% chance of achieving a positive NPV.

Fig. 4 shows the average NPV for the next scenario: 15 acres dedicated to biodiesel production.

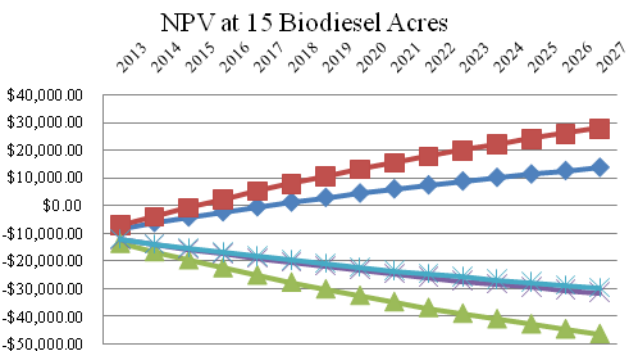

Fig. 4. Based on the average NPV results, Corn and Canola achieve a positive ROI within 3 and 5 years respectively. No other crops achieve a positive ROI. Sunflower and Soybean are almost identical in average NPV in Fig. 4.

When increased to 15 acres, Canola has a 90% chance of achieving a positive NPV. Corn increases to an 86% chance. Peanut and Soybean have a 0% chance of a positive NPV. Sunflower has less than 1% chance of a positive NPV.

Fig. 5 shows the average NPV for the next scenario: 20 acres dedicated to biodiesel production.

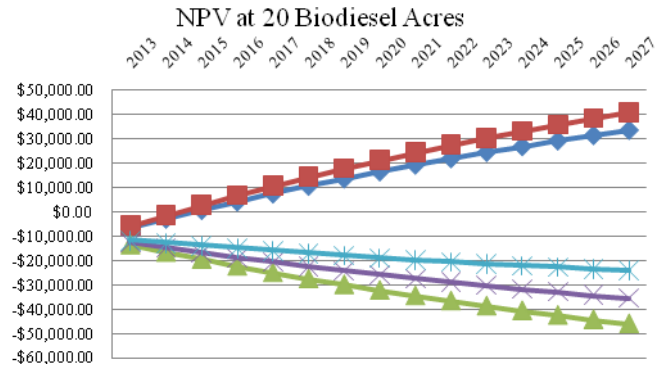

Fig. 5. Based on the average NPV results, Corn and Canola each achieve a positive ROI within 2 years. No other crops achieve a positive ROI.

At 20 acres producing biodiesel, there is a 99% chance of a positive NPV when using Canola. Corn increases to an 88% chance of a positive NPV. Peanut and Soybean have 0% chance of a positive NPV. Sunflower increases to a 10% chance of a positive NPV.

As the number of acres committed to biodiesel increases, the mean NPV for Corn and Canola and the probability of a positive NPV increase significantly. Increased acreage has a minimal negative impact on Peanuts and Soybeans and a minimal positive impact on Sunflower. Scenarios with the higher discount rates of 5% and 7% mirror these results but with numbers of smaller magnitude.

C. Sensitivity Analysis

Sensitivity analysis was conducted for the price of diesel and the number of acres committed to biodiesel production. In order for Peanut to produce a positive NPV, diesel prices would have to increase to 13.00, 7.50, and 6.50 dollars per gallon for 10, 15, and 20 acres of biodiesel production respectively. Varying the number of biodiesel acres and diesel prices cannot result in a positive NPV for Soybeans. Sunflower could attain a positive NPV if the number of biodiesel acres increased to 42 or if the price of diesel increased to 17.50 and 8.50 dollars per gallon for 15 and 20 biodiesel acres respectively.

D. Utility Analysis

In order to determine the best crop alternative, three factors were analyzed in a value hierarchy: (1) Biodiesel yield in gallons per acre with a weight of 0.5, (2) Length of planting and harvesting season in days with a weight of 0.3, and (3) Hazard level associated with biodiesel production with a weight of 0.2. These factors and their weights were determined through discussion with the project sponsor. Maximizing the biodiesel yield per acre is essential to minimizing the number of biodiesel acres and in turn the impact on food supplies. The length of the planting and harvesting season measures the time until biodiesel can be produced – a shorter time is more desirable. The hazards associated with biodiesel production all stem from the chemicals and catalysts that are mixed with the vegetable oil. Thus, all of the crop alternatives have the same level of

hazard. The method of analysis includes evaluating the utility of each alternative in comparison to the NPV in order to determine the best crop alternative. Fig. 6 shows the utility for each crop alternative plotted against the NPV (ranged from the minimum to the maximum on the 90% confidence interval) for 20 acres committed to biodiesel production.

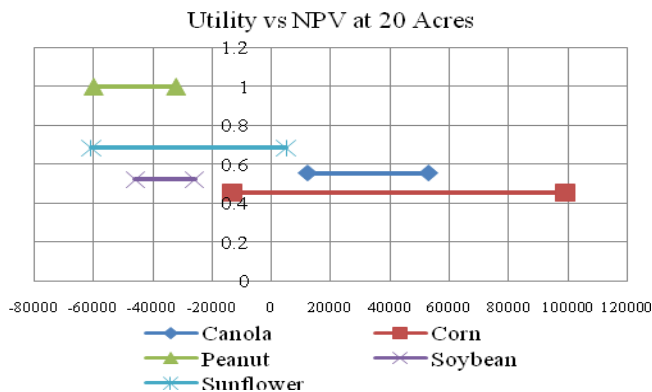

Fig. 6. Utility vs Net Present Value

The results of the utility analysis show that Peanut has the highest utility but also the lowest NPV. Corn has the highest NPV but also the lowest utility and high NPV variability. Soybean and Sunflower both have moderate utility but a negative NPV. Canola has the middle utility but a positive NPV. Table IV shows the alternatives ranked according to utility.

TABLE IV
RESULTS WITH UTILITY AND NPV

Crop	Biodiesel Yield	NER	Season Length	Utility	NPV
Peanut	136	4.09	170	1	-46000
Sunflower	62	3.05	170	0.68	-24100
Canola	102	3.43	265	0.55	33700
Soybean	35	1.77	185	0.52	-35500
Corn	19	0.84	185	0.45	40800

Peanut, Soybean, and Sunflower all have a negative NPV which makes them infeasible to implement. Corn has a positive NPV but the low biodiesel yield results in a low utility value. If the corn yield increased significantly, Corn could produce more biodiesel and become a more viable option. Canola's long planting and harvesting season results in a low level of utility. The high biodiesel yield allows the farmer to sell the excess biodiesel for a profit.

VIII. RECOMMENDATIONS

Farmers committing 20 acres to biodiesel production utilizing Canola can achieve a positive ROI within 2 years. When utilizing 20 acres of farmland, the Canola NPV distribution has a 99% probability of achieving a positive NPV at the end of 15 years at the 2% discount rate.

Although biodiesel production using Corn is profitable, it does not provide sufficient biodiesel for the average farm's need and does not meet the minimum net energy ratio

requirement. With the existing price for diesel, biodiesel yield per acre, and planting and harvesting expenses, biodiesel production using Peanut, Soybean, or Sunflower is not profitable.

It is recommended that farmers in the Fredericksburg area of Virginia implement biodiesel production using Canola. Furthermore, by committing additional acres of land to biodiesel production farmers will be able to sell the unused biodiesel for a profit.

ACKNOWLEDGMENT

The authors would like to thank Dr. Terry Thompson for his contribution as the sponsor of this project. Also, special thanks to instructors Dr. Lance Sherry (lsherry@gmu.edu), Mr. Juan Mantilla, and Miss Lewis for contributing to the completion of this project.

REFERENCES

- [1] USDA Census of Agriculture, *2007 Census, Volume 1, Chapter 2: County Level Data*, [online] 2007, http://www.agcensus.usda.gov/Publications/2007/Full_Report/Volum_e_1_Chapter_2_County_Level/Virginia/. Accessed 14 October 2012.
- [2] USDA Census of Agriculture, *2007 Census of Agriculture- Small Farms*, [online] 2007, http://www.agcensus.usda.gov/Publications/2007/Online_Highlights/Fact_Sheets/Farm_Numbers/small_farm.pdf.
- [3] USDA Census of Agriculture, *2002 Census of Agriculture- Small Farms*, [online] 2002, <http://www.agcensus.usda.gov/Publications/2002/index.php>. Accessed 14 October 2012.
- [4] USDA Census of Agriculture, *1997 Census of Agriculture- Small Farms*, [online] 1997, <http://www.agcensus.usda.gov/Publications/1997/index.php>. Accessed 14 October 2012.
- [5] United States Energy Information Administration. [online] http://www.eia.gov/dnav/pet/hist/LeafHandler.ashx?n=p&s=emd_cp d2d_pte_nus_dpg&f=a. Accessed September 2012.
- [6] American Society for Testing of Materials. [online] <http://www.astm.org/Standards/D6751.htm>. Accessed October 2012.
- [7] S. Fore, W. Lazarus, P. Porter, N. Jordan, "Economics of small-scale on-farm use of canola and soybean for biodiesel and straight vegetable oil biofuels", *Biomass and Energy*, Volume 35, Issue 1, January 2011, Pages 193-202. [online] <http://www.sciencedirect.com/science/article/pii/S0961953410002722>
- [8] S. Hoover, "Energy balance of a grassroots biodiesel production facility." [online] <http://www.biofuels.coop/education/resources/energy-balance>.
- [9] United States Bureau of Labor Statistics. [online] http://www.seattle.gov/financedepartment/cpi/documents/US_CPI_Fo recast_-_Annual.pdf
- [10] D. Lopes, A. Neto, P. Martins, "Economic simulation of biodiesel production: SIMB-E tool," *Energy Economics*, 2011. [online] <http://dc309.4shared.com/doc/svE7tmgX/preview.html>
- [11] D. Starmer, A. Hamama, H. Bhardwaj, "Prospects of canola as an alternative winter crop in Virginia, 2002. [online]. <http://www.hort.purdue.edu/newcrop/ncnu02/v5-127.html>
- [12] USDA, National Agriculture Statistics Service, *Crop Production*. [online] usda01.library.cornell.edu/usda/ers/89002/Table15.xls
- [13] USDA, National Agriculture Statistics Service. [online] www.ers.usda.gov/datafiles/Oil_Crops_Yearbook.../table20.xls
- [14] USDA, National Agriculture Statistics Service. [online] www.ers.usda.gov/datafiles/Oil_Crops_Yearbook_2012/table2.xls